

MKDX TOP ASSEMBLY - P/N 165175

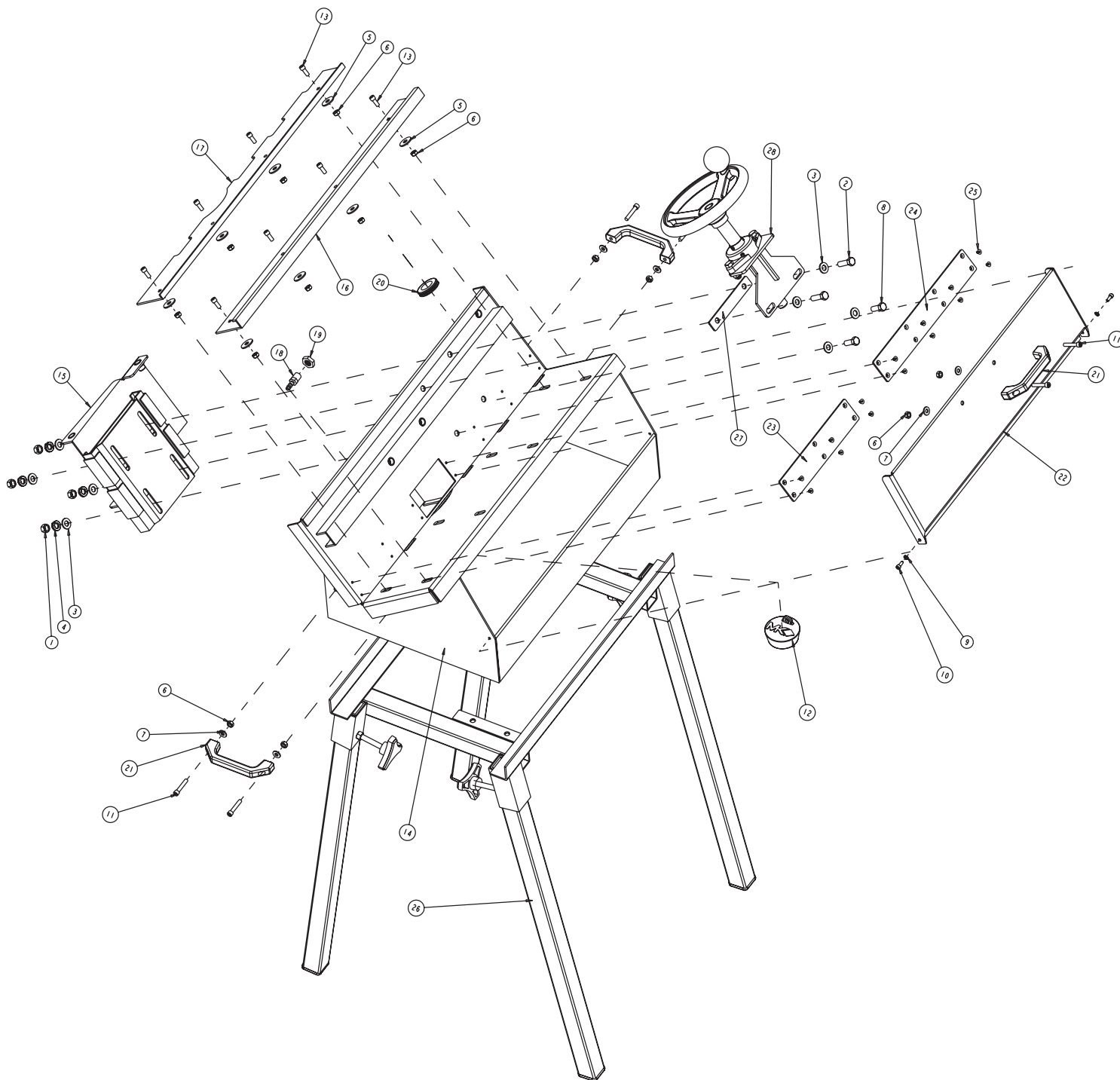

ITEM	DESCRIPTION	PART#	QTY.
1	NUT, 3/8-16 HEX	101188	4
2	SCREW, 3/8 - 16 X 1-1/4 HEX HEAD CAP	150774	2
3	WASHER, 3/8 SAE FLAT	150923	8
4	WASHER, 3/8 SPLIT LOCK	150925	4
5	5/16 FENDER WASHER	151053	8
6	NUT, 1/4-20 HEX	151893	14
7	WASHER, 1/4 SAE FLAT	151915	6
8	SCREW, HEX HD CAP, 3/8-16 X 1	152507	4
9	WASHER, #10 SPLIT LOCK	153684	2
10	SCREW, 10-32 X 1/2 SOCKET HEAD SET	157525	2
11	SCREW, SOC HD CAP, 1/4 - 20 X 1-1/4	159336	6
12	PLUG, 2-1/2 DIA RUBBER	159858	1
13	SCREW, 1/4 - 20 X 5/8 SOCKET HEAD CAP	161269	8
14	TRAY WELDMENT	165169	1
15	MOTOR GUIDE ASSEMBLY	165171	1
16	GUIDE "C2"	165179	1
17	GUIDE "L"	165180	1
18	FITTING, PUSH ON HOSE 1/4 X 1/4 MALE	165183	1
19	NUT, BRASS 1/4 NPTF	165184	1
20	GROMMET	165185	1
21	HANDLE, PULL	165187	3
22	DOOR	165212	1
23	PROTECTIVE STRIP	165213	1
24	PROTECTIVE STRIP	165214	1
25	FHCS #8-32 X 5/16"	165481	14
26	STAND ASSEMBLY	166304	1
27	SPACER	166565	1
28	HAND WHEEL ASSEMBLY	166635	1

**MKDX MATERIAL SLIDE ASSEMBLY - P/N 165170**

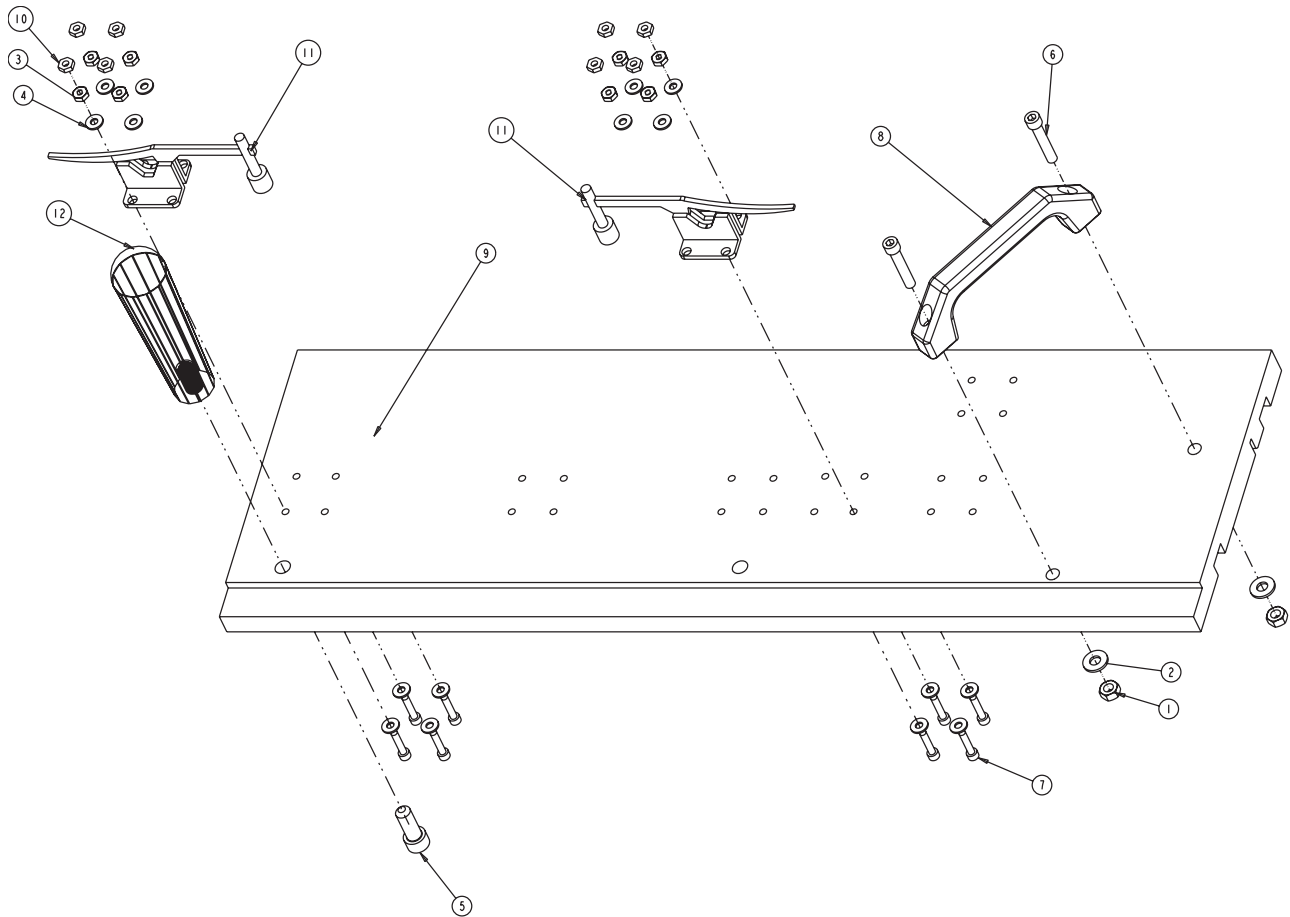

ITEM	DESCRIPTION	PART#	QTY.
1	NUT, 1/4-20 HEX	151893	2
2	WASHER, 1/4 SAE FLAT	151915	2
3	NUT, #8-32 HEX	153549	8
4	WASHER, FLAT #8	155454	16
5	SCREW, SOCKET HEAD CAP 3/8-16 X 1	156602	1
6	SCREW, SOC HD CAP, 1/4-20 X 1-1/4	159336	2
7	SCREW, 8-32 X 3/4 SOCKET HEAD CAP	164594	8
8	HANDLE, PULL	165187	1
9	MATERIAL SLIDE	165188	1
10	NUT, HEX JAM NYLON #8-32, 18-8	165227	8
11	CLAMP, TOGGLE 200#	165273	2
12	HANDLE, VERTICAL	165474	1

**MKDX MOTOR GUIDE ASSEMBLY - P/N 165171**

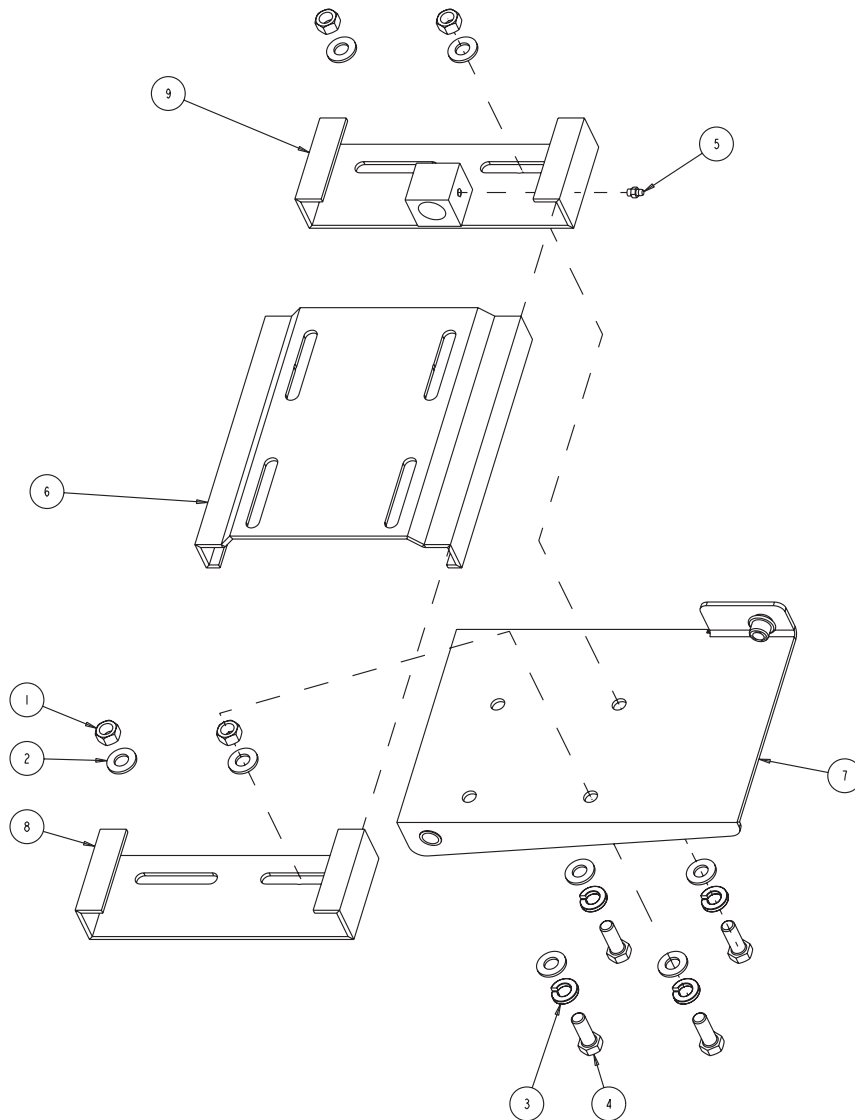

ITEM	DESCRIPTION	PART#	QTY.
1	NUT, 3/8 - 16 HEX	101188	4
2	WASHER, 3/8 SAE FLAT	150923	8
3	WASHER, 3/8 SPLIT LOCK	150925	4
4	SCREW, HEX HD CAP, 3/8 - 16 X 1	152507	4
5	FITTING, 1/4 - 28 GREASE	153852	1
6	MOUNTING PLATE	165190	1
7	SWIVEL MOUNT	165191	1
8	SLIDE	165193	1
9	PULL SLIDE ASS'Y	165580	1

MKDX SWITCH ASSEMBLY - P/N 165176

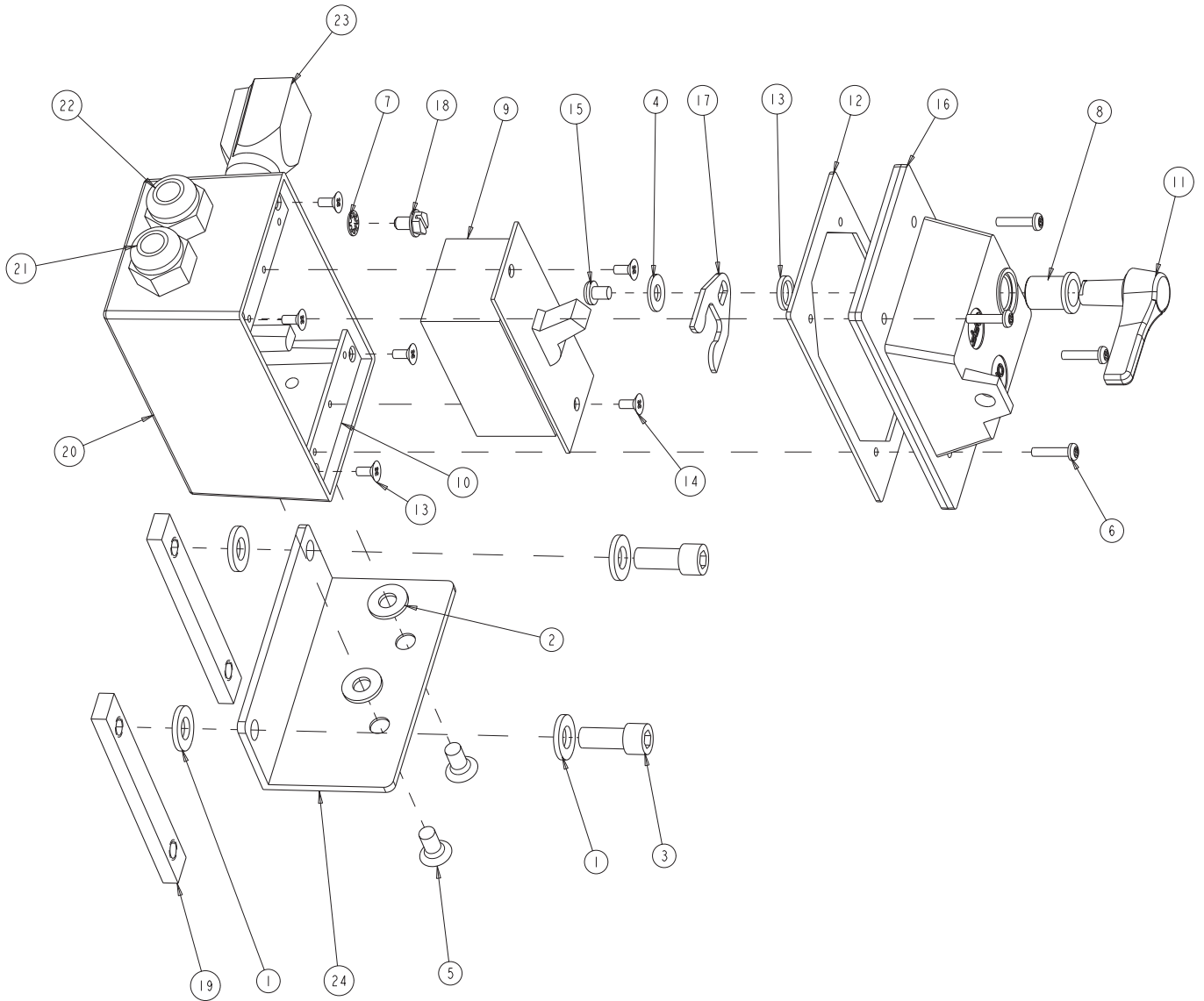

ITEM	DESCRIPTION	PART#	QTY.
1	WASHER, 5/16 SAE FLAT	151754	4
2	WASHER, 1/4 SAE FLAT	151915	2
3	SHCS 5/16-18 X 3/4"	152444	2
4	WASHER, #10 SAE FLAT	154369	1
5	SCREW, FLAT HEAD 1/4-20 X 1/2	155812	2
6	SCREW, PAN HD PHIL 6-32 X 5/8	157393	4
7	WASHER, #10, INTERNAL TEETH	158336	1
8	BUSHING, SWITCH, 30 AMP	158799	1
9	SWITCH, 30 AMP MOTOR CONTROLLER	159488	1
10	PLATE, MOUNTING SWITCH	159489	2
11	LEVER, ON/OFF, 30 AMP SWITCH	159490	1
12	GASKET, COVER, 30 AMP SWITCH	159491	1
13	SEAL, LEVER, 30 AMP SWITCH	159492	1
14	SCREW, FLAT HD PHIL 6-32 X 5/16	159493	6
15	SCREW, PAN HD PHIL 10-24 X 5/16	159494	1
16	COVER, 30A SWITCH (COMP)	159539	1
17	LEVER,ACTUATOR (COMP)	159540	1
18	SCREW,HEX HD FL 10-24 X 5/16	159597	1
19	KEY, MOTOR MOUNT	159859	2
20	BOX, 30A SWITCH (COMP)	159865	1
21	MOTOR CORD	159907	1
22	POWER CORD	159908	1
23	PUMP CORD	159909	1
24	SWITCH BRACKET	165222	1
25	WIRE NUT 14/16 YELLOW	159968	1

## MKDX DRIVE TRAIN ASSEMBLY - P/N 165172

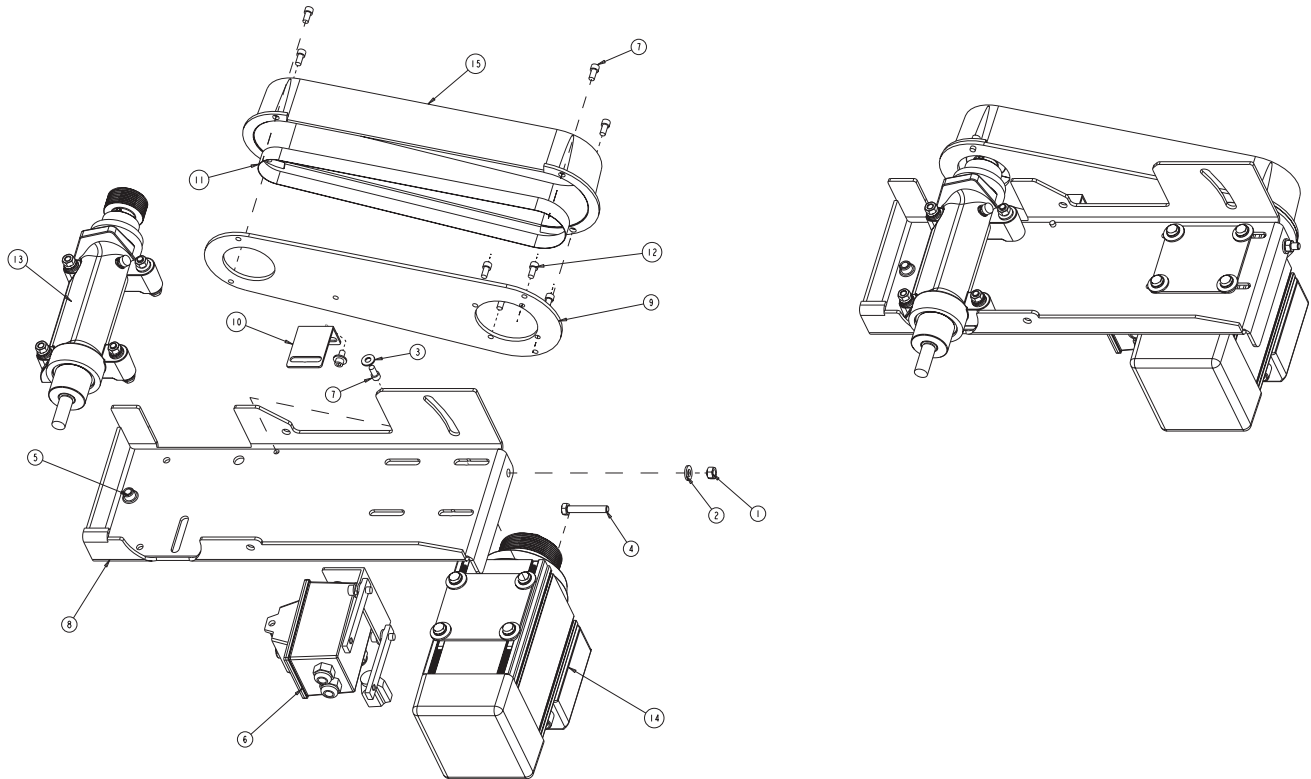

ITEM	DESCRIPTION	PART#	QTY.
1	NUT, 5/16-18 HEX	101196	1
2	WASHER, 5/16 SAE FLAT	151754	1
3	WASHER, 1/4 SAE FLAT	151915	2
4	SCREW, HEX HEAD MACHINE 5/16-18 X 2	157938	1
5	INSERT, 3/8-16 AVK	158193	1
6	SWITCH ASSEMBLY	165176	1
7	SCREW, 1/4-28 X 1/2 SOCKET HEAD CAP	165177	6
8	DRIVE TRAIN MOUNT	165197	1
9	BELT GUARD PLATE	165202	1
10	BELT GUARD BRACKET	165203	1
11	BELT, MICRO V 32"	165210	1
12	SCREW, 1/4-20 X 1/2 SOCKET HEAD CAP	165211	4
13	ARBOR ASSEMBLY	165218	1
14	MOTOR ASSEMBLY	165219	1
15	BELT GUARD	165579	1

**MKDX FILTER ASSEMBLY - P/N 165438**

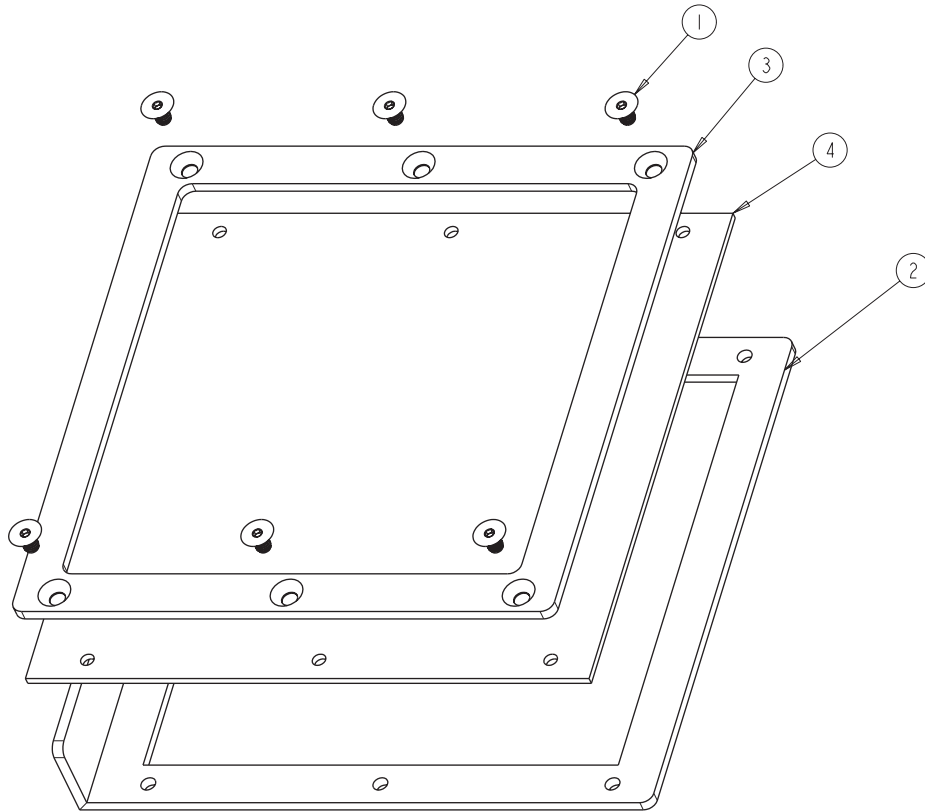

ITEM	DESCRIPTION	PART#	QTY.
1	FILTER FRAME	165439	1
2	FILTER HOLDER BAR	165440	1
3	FHCS #8-32 X 5/16	165481	6
4	FILTER COMPLETE	165919	1